

**AUTOMATION ALGORITHM AND INSTALLATION FOR SEQUENTIAL
PROCESSES FOR THE TREATMENT OF TOXIC WASTEWATER WITH
HIGH ORGANIC CONTENT**

Laurentiu Dinu, Costel Bumbac, Elisabeta Pena-Leonte, Anca Popescu

National Research And Development Institute For Industrial Ecology ECOIND
Bucharest, 90-92 Panduri Road, 050663, Bucharest, sector 5, Romania, e-mail:
ecoind@incdecoind.ro

ABSTRACT

Biological treatment of wastewater, including industrial, is often applied, due to economic and also technical performance. However, the pollution of the industrial wastewater is determined in many cases by complex mixtures of organic and inorganic species and their removal could necessitate multi-stadia phases, i.e. aerobic and anaerobic conditions, but also employment of such measures that mitigate the toxic character of pollutants over biomass.

The sequencing batch reactors (SBR) separate the process phases in time (one phase starts after the previous one is finished), using a single reaction tank and are basically unsteady, unlike the activated sludge with continuous flow, when separate tanks are used for different phases with steady conditions.

This paper presents some achievements for exploiting the SBR flexibility by adjusting the feeding algorithm and the duration of different phases. Such

algorithms were tested for high concentrated phenolic solutions, up to near 3 g/l and ammonium rich (250 mg/l) phenolic solutions, with the aim of complete phenol removal and also complete denitrification. Testing lab installation was controlled by PLC (with user free adjustment of parameters for feeding strategies and duration of sub-phases) and the algorithms were successful in mitigation of toxic effect of the phenol. Next stage is a transition to a data acquisition and control system (computer based) which will allow automatic phase switching by identification of critical points by first and second order derivative processing of monitoring data, i.e. for pH, ORP, DO.

Keywords: SBR, phenol, denitrification, phase end-point, DAQ

INTRODUCTION

For the biological wastewater treatment, the aerobic and anaerobic processes have kinetic and metabolic limit conditions, so there are cases when multi-stadia technologies have to be used, such as nitrification and denitrification and other successive oxidation and reduction steps (are to be employed).

The sequences / reaction phases can be separate in space (e.g. continuous flow, stationary processes) or in time – the case of the sequencing batch bioreactors (SBR). In case of SBR, different reaction and separation phases are proceeding in one space (such as aerobic biological treatment followed by solids settling and supernatant withdrawal).

On the another hand, the sequencing batch reactors allow the changing of operational conditions in cyclic sequences (e.g. aerobic, anoxic). The alternation of operation sequences can lead to good quality for effluents, from the point of view of global organic load or specific parameters, such as nitrogen compounds.

The complexity of operational cycles can be adapted to the characteristics of the influent and also to the water treatment requirements, different process algorithm being possible to be applied. For example to remove nitrogen compounds from the wastewater it is necessary to create the proper conditions for two processes: nitrification (aerobic) and denitrification (anoxic and limited by carbon source). The SBR can combine the two processes in a single reactor. Various operational strategies can be used, the most common being with a single filling phase followed by successive anoxic and aerobic phases and finally settling. This operational algorithm, basically one filling phase followed by reaction is named {filling – react}.

Due to the flexibility of SBR systems, the operational strategies can be more complicated, some of them leading to an increase in the bioreactor efficiency by modifying the way the filling is done, as a sequential process itself within the global operational scheme of the bioreactor (operational algorithms of type {[fill+react]-[react]}). Such strategies, using filling the SBR with low and constant or variable flow rate can lead to good results when industrial wastewaters containing toxic species are to be treated and also when the concentrations of these species are variable.

EXPERIMENTAL PART

This study was based on two control strategies:

A. For the case when the wastewater to be treated has a toxic / inhibitory character for the biomass, when it is not permitted to exceed a limit concentration for which the process stops and/ or the biomass is compromised. The bioreactor has to be fed in correlation with the target pollutant consumption rate (with a small constant feed-flow or a pulse-feeding), that's so the concentration will remain at levels at which the process is not inhibited (Fig. 1). This could be the case of resin fabrication or coke plant effluents.

B. For other cases where there is a need to have a succession of oxic and anoxic phases and also to control the balance of reduced or oxidized forms / species by changing the timing for feeding and how this is done.

In this case, the feeding algorithm (Figure 2) will follow, for example, the needs for the substrate (quantitatively deficient or which can be quickly consumed by competitive biological pathways). A typical case is that of simultaneous organic carbon aerobic oxidation (heterotrophic) and nitrification (autotrophic) followed by organic carbon oxidation in denitrification. In this case, the aerobic phase can deplete the organic substrate in parallel process with nitrification (which is determinant for the phase length), not leaving enough reducing substrate for the next step, anoxic denitrification – so the global efficiency will be low. In Figure 2 flow diagram, if the feed is done out of the internal cycle, it will have low influence on process control, on steering the balance of reduced or oxidized species for various phases.

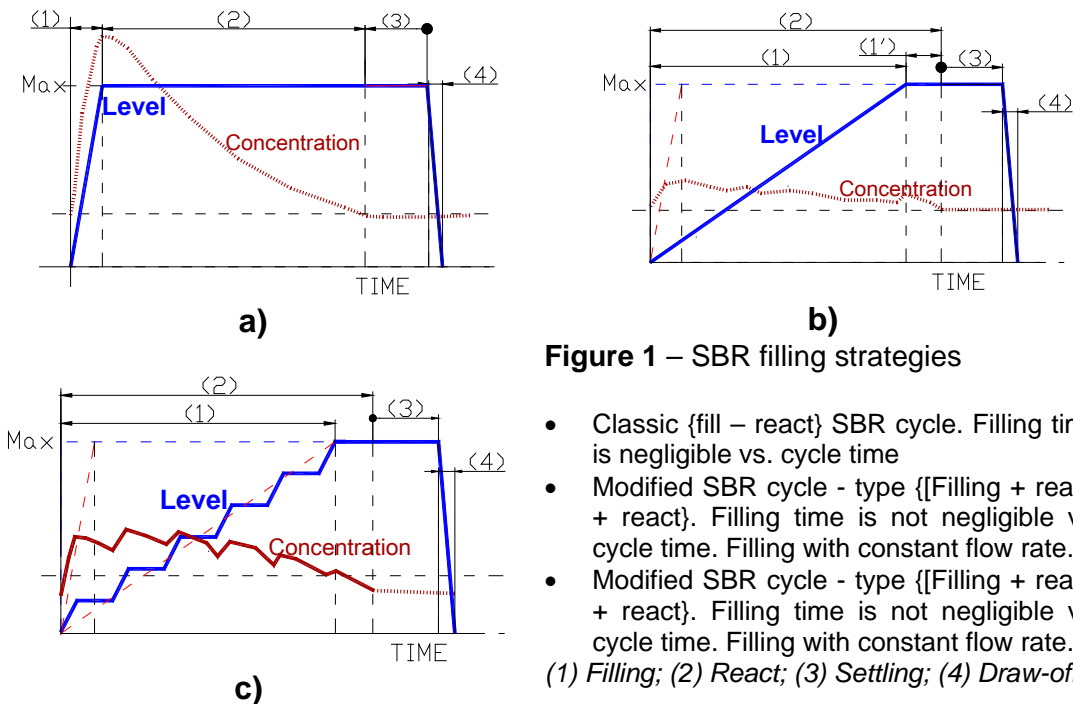

Figure 1 – SBR filling strategies

- Classic {fill – react} SBR cycle. Filling time is negligible vs. cycle time
 - Modified SBR cycle - type {[Filling + react] + react}. Filling time is not negligible vs. cycle time. Filling with constant flow rate.
 - Modified SBR cycle - type {[Filling + react] + react}. Filling time is not negligible vs. cycle time. Filling with constant flow rate.
- (1) Filling; (2) React; (3) Settling; (4) Draw-off

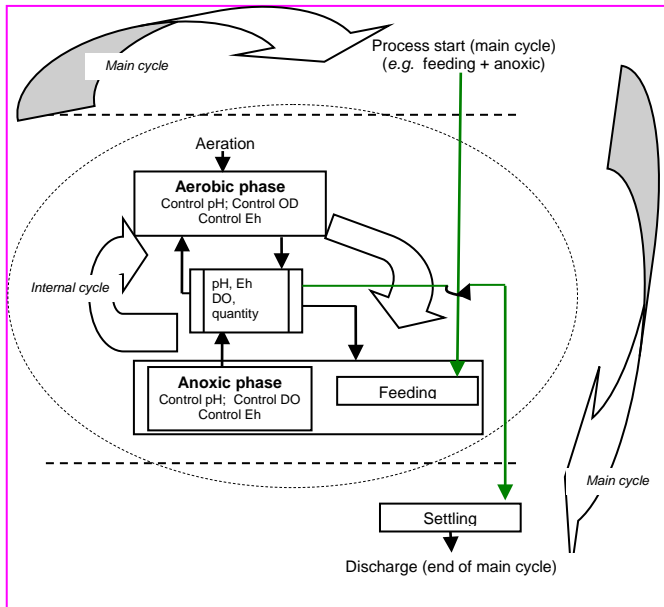

Figure 2 –SBR cycle with internal {Filling and react} phases
 Phases are facultative aerobic or anoxic.

A schematic of the experimental laboratory-scale SBR used to test the above concepts is given in Figure 3. The set-up mainly consists of column type bioreactor (with a working volume of 6 to 8 L), equipped with fine bubble gassing system (air, N₂), feeding and discharging pumps and valves. The pumping rate can be adjusted by the pumping frequency and ON time interval via the PLC (concept A). For the concept B, the main cycle and the internal cycle sequencing (aerobic/ anoxic phase + feeding) are done also by the PLC which also counts the number of coupled phases (limited in program). The duration for each phase of the operation cycle can be set independently. The pH can be controlled with a proportional dosing pump using a 4-20 mA signal from the controller (pH adjustment with NaOH, e.g. during aerobic nitrification phases).

Mixing during anoxic phases is done with short periodic pulses of nitrogen to the gassing device.

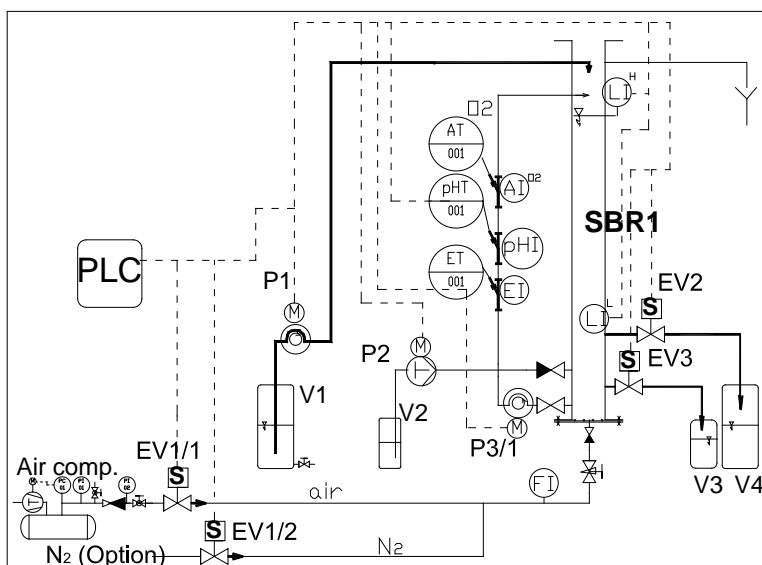

Figure 3 –
 Experimental set-up
 (the whole system comprises 3 reaction similar modules, not shown here, for simplicity)

Different algorithms- control strategies were tested for high strength phenol solutions and phenol plus ammonium chloride solutions.

RESULTS AND DISCUSSION

Tests with SBR for high and toxic organic load synthetic wastewater

Tests with phenol solutions, up to 3 g/l, using flocculent sludge

The aim of these experimental works was to test the {filling + aerobic react} strategy (similar as per Fig. 1-c), using a biomass not necessary specialised or very well adapted to the high toxic load, a case possible especially in industrial applications with different fabrications and / or when high variations are possible from one main fabrication. The inoculum was obtained using a municipal WWTP biological sludge which was at first adapted to increasing phenol concentration, starting from 20 mg/l phenol, raised to 250 mg/l. The sludge volume and filling volume were 1.8 L and 3 L respectively. The cycle and filling and aeration phases length were adjusted as exemplified in Table 1.

After an adaptation during two months to relatively low phenol concentrations, up to 250 mg/l, the system was tested for higher phenol concentrations, up to 2000 mg/L (2.5 kg/m³·day). The pH was controlled to 7.5-8.5 with automatic NaOH dosage (0.3N).

The upper limit phenol concentration for which the system worked steady was 1500 mg/L (COD-Cr ≈ 3800 mgO₂/L), respectively loads of 1.9 kg / (m³·day) phenol and 4.7 kg O₂/ (m³·day) as COD.

Effluent phenol concentration was typically < 0.001 mg/l and global organic load as COD-Cr was 70 to 120 mgO₂/l.

As the phenol load was increased, there was a need to increase also the settling time (quite easy for SBR), due to some loss of sludge settleability, which was more relevant above a phenol load of 0.7 kg/ (m³·day), but working sludge concentration in the mixed liqueur at maximum volume was steady at about 1 g/L (as dry solids). Above this limit, for a feeding with phenol at 2000 mg/L (2.5 kg/m³·day), the system loosed the stability; the sludge became deteriorated and was washed out in few days.

Table 1 - The cycle, filling and aeration phases length adjustment for a pulse feeding with constant flow rate

Phase	Phenol concentration, (mg/l)	Parameters				
		Cycle time Tech code	Ta1+r (min)		Ta2 (h)	Td (h)
			T1 (min)	T2 (min)		
Adaptation (2 months)	20-250	24 h	16		6.7	1h
		24/22/16	2	9		
Testing	250	12 h	9		1.5	1h15
		12/10.5/9	3	9		
Testing	400	12 h	9		1.5	1h15
		12/10:30/9	3	7		
Testing	550	12 h	9		1.5	1h15
		12/10.5/9	3	7		
Testing	700	12 h	9		1.5	1h15
		12/10.5/9	3	7		
Testing	1000	12 h	9		1.5	1h15
		12/10.5/9	3	7		

Testing (still stable)	1500	12 h 12/9.75/8.25	8.25		1.5	2h
			3	7		
Testing	2000	12 h 12/9.75/8.25	8.25		1.5	2h
			3	7		
<i>T a1+r</i> = Feeding and reaction time (overlapped) ; <i>Ta2</i> = Reaction time after feeding T1- feed pump ON; T2 – time, feed pump OFF; Td = settling time Feeding time T1 is set as to obtain a total feed volume of 3 L, correlated with (<i>Ta1+r</i>) and pump flow rate, adjusted between 0.6 to 1.2 L/h.						

Tests with phenol solutions, up to 3.5 g/l, using granular sludge

The system was used with a {fill – react} cycle (Figure 1-a) to grow and to adapt granular sludge. Sludge granules showed good biomass stability and retention, together with good metabolic activity and settling characteristics, up to phenol concentration of 2.5 g/L, load 3.2 kg/ (m³·day). The settling behaviour of the granular sludge is worsening with the increase of phenol concentration in feed. The phenol degradation rate decrease for higher feed concentrations, e.g. for phenol concentrations from 1500 mg/l up to 2700 mg/l, the degradation rate decrease with about 50%, from 0.16 to 0.09 mmol/(dm³·min).

Even the compact structure of granules protects the microorganisms against toxic level of the phenol concentration in the bulk solution, the compactness of the sludge is compromised above 3 g/L and it is quickly washout at 3.5 g/L (total system failure). These are described in more detail elsewhere [2] and are briefly mentioned here only as an element of comparison for the use of flocculent sludge, as here, less adapted, in conjunction with SBR operation algorithms.

When the SBR system was used with an operation algorithm of type {filling + react}, the efficiency in removing a toxic substrate – phenol was satisfactory. This SBR operating system can withstand peak influent concentrations, because the shock load is avoided by the feeding algorithm itself. Even using a biomass not well adapted or not in forms for which the resistance to toxicity is higher, the efficiency and stability, is comparable with such other reaction systems, e.g. granular sludge or attached film found in related research works [1, 2,3]. Here the SBR was push to the limit for certain operational parameters, but most probably those can be tuned for higher performance (e.g. by lengthen the filling time together with decreasing the flow rate).

Tests for high strength phenol and ammonium chloride solutions

For the treatment of aqueous system phenol and ammonium, using different SBR strategies, it was used a flocculent sludge adapted for phenol concentrations of 500 mg/L in a {fill – react} control algorithm. The test feed solution contains among phenol (500 mg/L), ammonium (up to 250 mg/l), supplied as NH₄Cl. The chemical oxygen demand is increased with sodium acetate (1g/L). The loads applied, reported to nitrogen and organic substrate expressed as COD-Cr was 0.2 kg N/ (m³·day), respectively 2.5 kg O₂/ (m³·day). For the phenol and ammonium solution, the SBR was tested using the following operation algorithms:

Algorithm “1”: {Fill – react}, filling followed by aerobic phase, with a total cycle time of 12 h.

Algorithm “2”: {[Fill + react]-react}. Feeding in anoxic regime, followed by an aerobic phase (this succession of internal phases are iterated inside the main cycle of 12 h (similar as described by Figure 2).

The above algorithms were tested on the automatic installation (the second cannot be done manually).

Algorithm “1” for the phenol-ammonium system, {filling - aerobic react}

The first noticed effect of the phenol presence in the system was the nitrite production and accumulation (further oxidation to nitrate was inhibited).

Slowly, the system has adapted for the NO_2^- oxidation to NO_3^- , but the final concentration of NH_4^+ remained relatively high (Figure 4b), globally it seems that the nitrifiers growth is inhibited by the high concentration of phenol at cycle start-up, even this substance is completely degraded in time. The total nitrogen removed was about 50% using this type of cycle (aerobic).

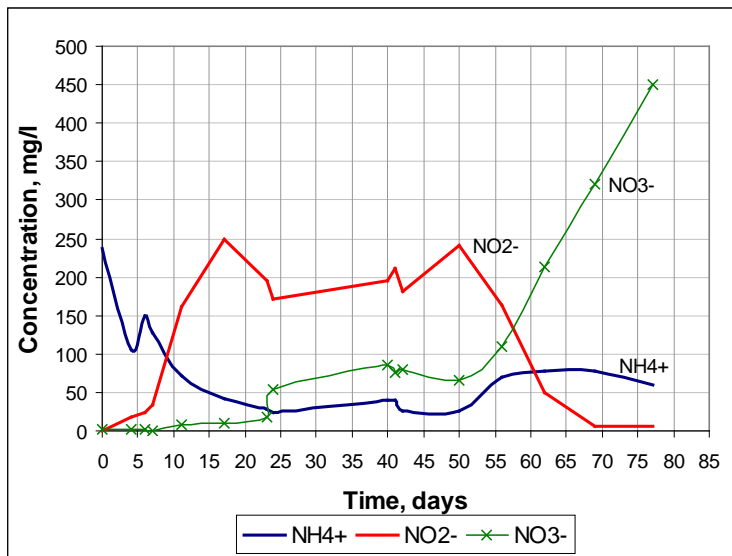

Figure 4 -
Phenol-ammonium SBR
behaviour in time,
algorithm “1” (filling and
aerobic reaction)

Algorithm “2” for the phenol-ammonium system (successions of filling+ anoxic react phase followed by aerobic react phase)

This algorithm is needed because the sequencing batch bioreactor working using algorithm “1” does not achieve denitrification. Algorithm “2” facilitates:

- the decrease of nitrite concentration / nitrite accumulation, which can inhibit the oxidation to nitrate
- the reduction of peak phenol concentration, which can inhibit the nitrifiers growth
- keep the organic carbon available for denitrification, in parallel with avoiding the carbon oxidation and nitrification running in parallel

The algorithm “2” was tested with up to ten sub-cycles of filling + anoxic react phase followed by aerobic react phase. Those are followed by other finishing anoxic and aerobic cycles, but without feeding. In time, few adjustments of the internal length of phases and the number of internal cycles were needed to enhance nitrification or denitrification, in a main cycle with a total reaction time

restricted to 11h (Figure 5). The variants were recorded as “regimes”. The results were good for the phenol, chemical oxygen demand and nitrogen compounds by nitrification and denitrification (Figure 6). The evolution of nitrogen species inside an internal sub-cycle is shown in Figure 7. Cycling of other process parameters within main cycle can be followed in Figure 8.

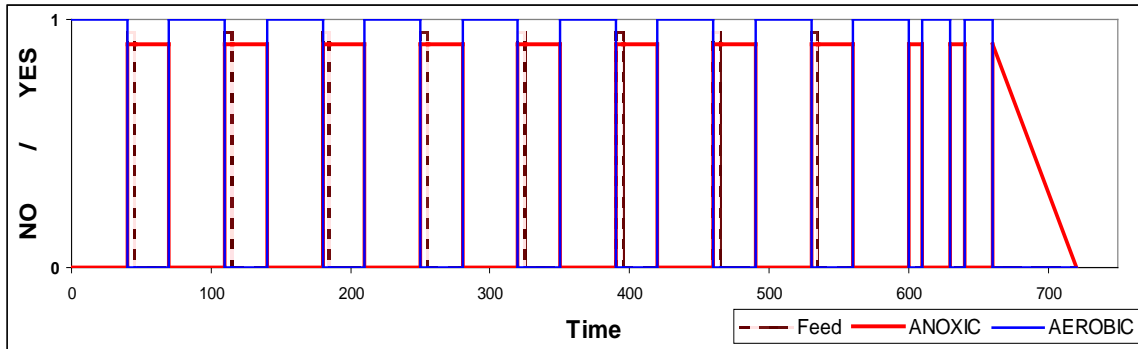

Figure 5 - Schematic diagram for the main cycle of the algorithm “2”, SBR with sequential filling in anoxic phase followed by the aerobic react phase

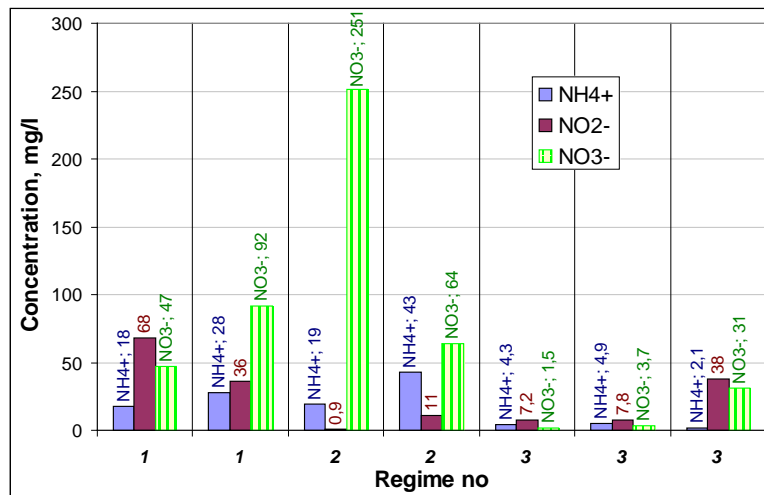

Figure 6 – Efficiency of SBR, algorithm “2”, working with phenol-ammonium solutions operating regime adjustments

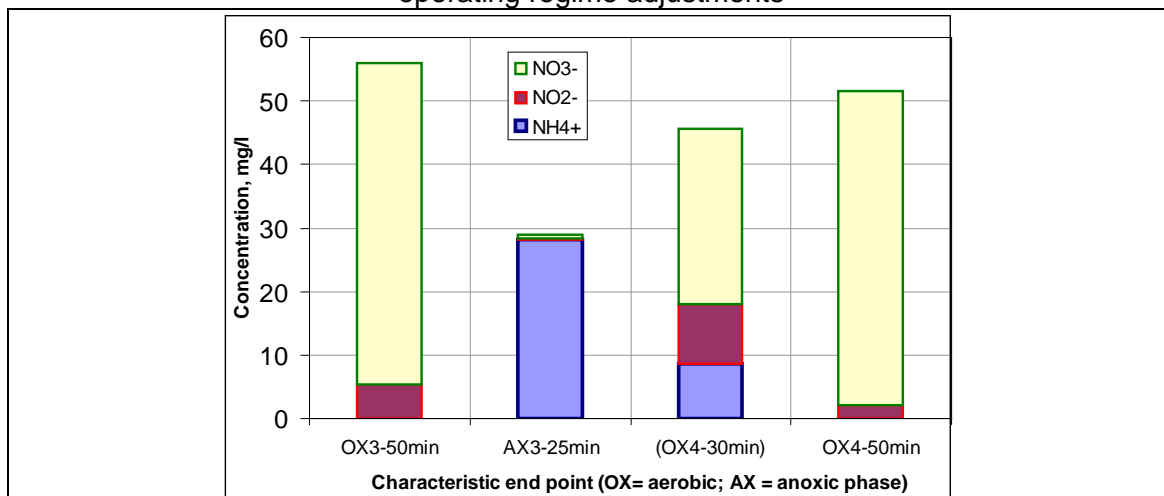

Figure 7 – Concentration of species with nitrogen for characteristic points of a sequencing sub-cycle (algorithm “2”, solution phenol-ammonium feed)

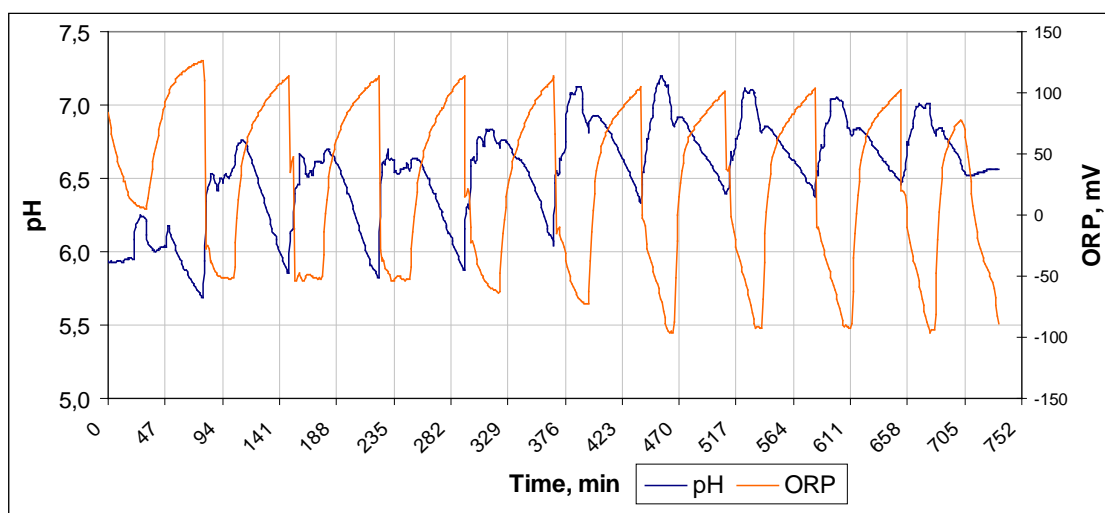

Figure 8- Cycling of pH and ORP within main cycle

For such applications, an algorithm which will allow automatic phase switching by identification of critical points by first and second order derivative processing of monitoring parameters for pH, ORP, DO may be necessary to handle input variability [4] and a transition to a SBR operated with data acquisition and control system, computer based was made.

CONCLUSION

In this work algorithms for SBR operation with flocculent sludge were tested for high strength synthetic wastewater containing phenol and phenol together with ammonium.

Using different algorithms, the SBR can handle high concentrations of toxic substances, avoiding critical levels for biomass due to shock loads, having a flexibility that recommends this system for industrial wastewater treatment applications with high variability. Such algorithms may have even better results if used with other biomass type than flocculent sludge, possibly with granular sludge or attached biomass.

Also, the SBR can support more complex operation algorithms for nitrification and denitrification in the presence of toxic substrates.

References:

1. G. Moussavi, M. Mahmoudi, B. Barikbin, *Biological removal of phenol from strong wastewaters using a novel MSBR*, Water Research **43**: 1295– 1302, 2009
2. C. Bumbac, R. L. Dinu, A. Popescu, E. Pena-Leonte, *Phenol rich wastewater treatment using an aerobic granular sludge SBR*, ARA Scientific and Technical Conference Development of the water supply and sewerage systems in the rural communities, 15-16th June 2010

3. B. Li, Y.L. Sun, Y. LI, *Pretreatment of coking wastewater using anaerobic sequencing batch reactor (ASBR)*, Journal of Zhejiang University Science, 6B(11):1115-1123, 2005
4. S. Marsili-Libelli, A. Spagni, R. Susini, *Intelligent monitoring systems for long-term control of Sequencing Batch Reactors*, Water Science and Technology, **57**(3):431-438, 2008